



TC 6R BIG BRAKE FRONT HAT KITS

KIT FEATURES

Complete systems with forged aluminum hubs for use on conventional front spindles and struts

Big brake looks and stopping power to compliment wheel, tire, and suspension system upgrades

 Calipers available in black

 Calipers available in red

TC 6R Big Brake
Front Hat Kit with SRP Rotor



KIT COMPONENTS

FORGED BILLET TC 6R PISTON CALIPERS

The TC 6R radial mount, six piston truck caliper represents a complete new generation from Wilwood. An extensive design, development, and testing program resulted in an extreme high strength caliper capable of generating the clamping force and durability necessary to handle the heavy loads of custom and performance modified pickup trucks and sport utility vehicles.

The foundation of the TC 6R is the FEA structural analysis designed forged billet body. Premium billet aluminum alloy blanks are stress flow forged to produce a caliper that minimizes weight while providing an extremely rigid and deflection resistant body. The bridge radius has been increased to accommodate rotors up to a full sixteen inches in diameter. The bodies are joined and heavily reinforced with six high strength steel cross bridge bolts. Cross bridge bolts give added strength against deflection and body separation at the high pressures and heavy loads generated by the power brake systems on late model trucks and SUV's. Steel bridge insert plates provide maximum load bearing protection against wear and gouging from the pad edges at all levels of brake force.

The TC 6R generates unmatched pad clamping efficiency through six thick walled stainless steel pistons. The heavy piston wall adds one more measure of strength under heavy loads while the stainless steel resists corrosion and reduces heat transfer into the caliper body, seals, and fluid from the pads. The differential piston bore design, taken from Wilwood racing caliper technology, provides balanced pad loading with even wear properties at all temperatures and loads. Piston bore volumes are matched for complete compatibility with the output volumes and pressures of the OE master cylinders.

The total TC 6R package is capped off with rubber dampened fluid transfer tubes, recessed two-piece bleed screws, and bridge mounted pad load springs. The pad load springs eliminate vibration and rattle while providing additional dampening against the engagement harmonics that can contribute to squeal and other harsh brake noise. Choices of either a signature high luster anodized Wilwood black, or a special multi-process gloss red coating, enhance the pure stopping power of the TC 6R with a high tech style and custom look inside the wheel.

FORGED ALUMINUM ROTOR HATS

High strength forged aluminum hats are rib reinforced to carry extreme loads and eliminate unnecessary, power robbing rotational weight. Black anodizing prevents oxidation while adding to the custom look inside the wheel.

16" STAGGERED VANE DIRECTIONAL ROTORS

Large 16" Staggered direction vane rotors offer the highest cooling efficiency by maximizing the surface area and air circulation between the rotor faces.

SRP ROTORS

For custom, show, and high performance sport driving, SRP rotor kits offer the high-tech look and improved performance of a directional cross-drill and face slot pattern. In addition to their aesthetic appeal, the venting and cleaning action of the holes and slots will reduce pad glaze, dissipate surface heat, and minimize irregular pad build-up on the rotor faces. The results are smoother engagement with improved consistency and response at the pedal. Every SRP rotor is treated with a silver zinc wash to reduce corrosion on the areas of the rotor not kept clean by pad contact.

GT ROTORS

GT rotor kits feature Wilwood's ultimate competition rotor with full detail machining, asymmetrical face slotting and individual dynamic balancing. GT rotors run true and smooth with extended rotor life and pad wear on applications subject to higher sustained operating temperatures.

WILWOOD BRAKE PADS

Advanced formula high friction compounds have quick response, big stopping power, and extended fade resistance over OE compound pads. Low dust, low noise formulas are easy on the driver and the wheels. Specific information on Wilwood Smart Pad, PolyMatrix and ProMatrix brake pad compounds can be found on pages 58-60.

CALIPER BRACKETS AND HARDWARE

Radial mount caliper adapter brackets provide a secure and accurate method of attaching the caliper to the mount bosses on the original spindle. The brackets can be shimmed in two directions to compensate for production variances in the OE spindles and hubs, to precisely locate the caliper over the rotor at the correct height for proper pad to rotor radial alignment.

PLUMBING

Fittings and hoses for these kits must be ordered separately. Hose kits for each available application can be found next to the kit part numbers in the ordering information, or with the plumbing information on pages 55-57.

NOTE

Installation of Wilwood Disc Brake Kits may affect the wheel offset. Reference Wilwood wheel clearance diagrams available on our web site.

ORDERING INFORMATION: KITS

MAKE	YEAR	OE SPINDLE TYPE	NOTES	KIT PART NUMBERS		HOSE KIT
				BLACK CALIPER GT ROTOR	BLACK CALIPER SRP ROTOR	
Cadillac	Escalade, EXT	2002-05	Disc - 6 Lug	140-8992	140-8992-D	220-8998
	Escalade, ESV	2003-05	Disc - 6 Lug	140-8992	140-8992-D	220-8998
Chevrolet	Avalanche 1500	2002-05	Disc - 6 Lug	140-8992	140-8992-D	220-8998
	Avalanche 2500	2002-05	Disc - 8 Lug	140-8996	140-8996-D	220-8998
	Silverado 1500, Non Crew Cab	1999-05	Disc - 6 Lug	140-8992	140-8992-D	220-8998
	Silverado Pickup 2500 & 3500	2001-05	Disc - 8 Lug	140-8996	140-8996-D	220-8998
	Silverado Pickup Crew Cab	2001-03	Disc - 8 Lug	140-8996	140-8996-D	220-8998
	Silverado Pickup-8 Stud Wheels	2004-05	Disc - 8 Lug	140-8996	140-8996-D	220-8998
	Suburban 1500	2000-05	Disc - 6 Lug	140-8992	140-8992-D	220-8998
	Suburban 2500	2001-05	Disc - 8 Lug	140-8996	140-8996-D	220-8998
	Tahoe	2001-05	Disc - 6 Lug	140-8992	140-8992-D	220-8998
	Tahoe, Silverado Style	2000	Disc - 6 Lug	140-8992	140-8992-D	220-8998
Ford	F-150 Pickup (2WD Only)	2004-05	Disc - 6 Lug	140-9072	140-9072-D	220-9073
GMC	Sierra 1500, Non Crew Cab	1999-05	Disc - 6 Lug	140-8992	140-8992-D	220-8998
	Sierra Pickup 2500, 3500	2001-05	Disc - 8 Lug	140-8996	140-8996-D	220-8998
	Sierra Pickup Crew Cab	2001-03	Disc - 8 Lug	140-8996	140-8996-D	220-8998
	Sierra Pickup-8 Stud Wheels	2004-05	Disc - 8 Lug	140-8996	140-8996-D	220-8998
	Yukon	2001-05	Disc - 6 Lug	140-8992	140-8992-D	220-8998
	Yukon (Except Denali)	2000	Disc - 6 Lug	140-8992	140-8992-D	220-8998
	Yukon XL1500	2000-05	Disc - 6 Lug	140-8992	140-8992-D	220-8998
Yukon XL 2500	2001-05	Disc - 8 Lug	140-8996	140-8996-D	220-8998	
Hummer	H2	2002-05	Disc - 8 Lug	140-8996	140-8996-D	220-8998
	H3	2006	Disc - 6 Lug	140-9409	140-9409-D	Call

GROUP 01

FOR USER SERVICEABLE COMPONENTS ORDERING INFORMATION, SEE PAGE 50

MAJOR BRAKE KIT COMPONENTS

TYPICAL TC 6R BIG BRAKE FRONT HAT KIT

Major Components Identified

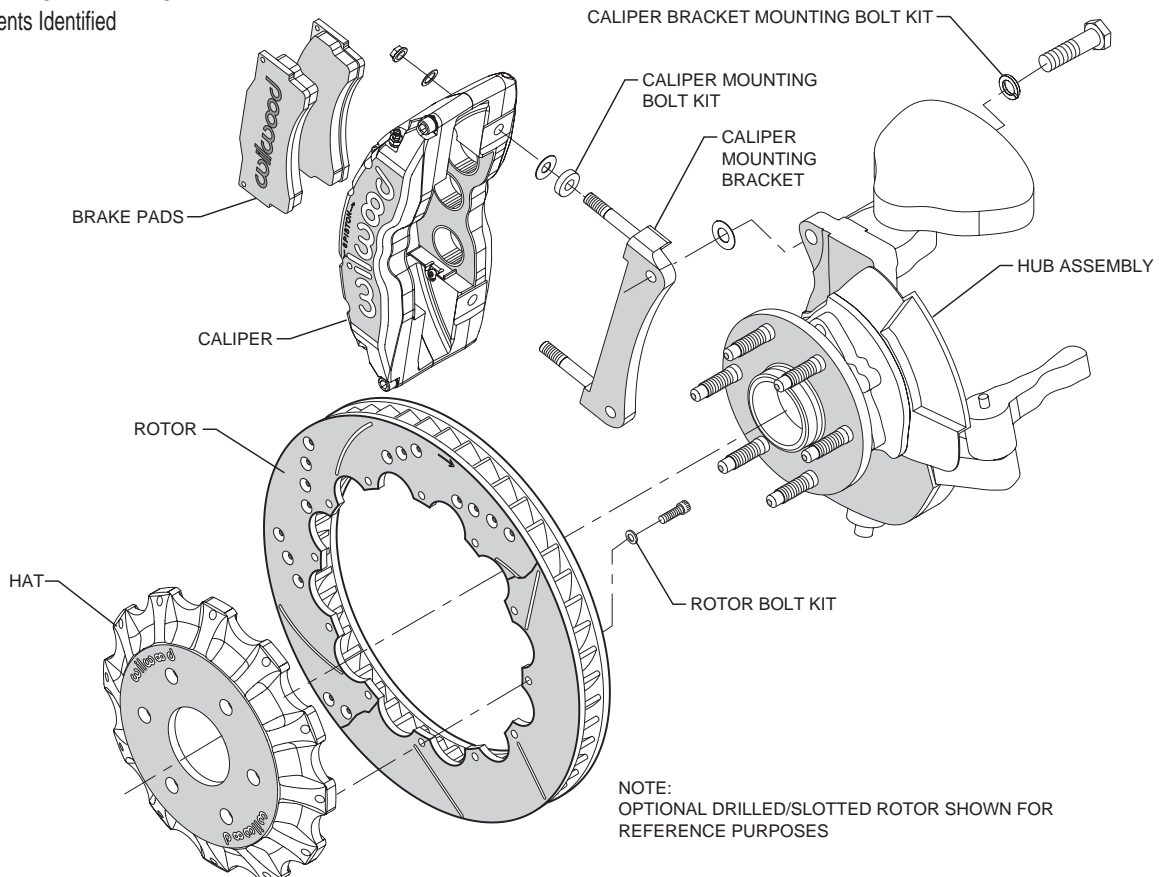

DISCLAIMER

Wilwood engineers brake kits and components for a wide variety of racing and high performance driving applications. It is the responsibility of the end user to choose the parts that are best suited for the braking demands encountered by his

or her vehicle. Vehicle speed and weight, along with environmental conditions should always be taken into account when selecting and installing the kit or component that's right for you. See page 9 for complete disclaimer of warranty.