



BILLET SUPERLITE 4 AND 4/ST LUG MOUNT CALIPERS

Caliper Highlights:

The billet **SL4** and **SL4/ST** calipers incorporate Wilwood's latest technology in a conventional 3.50" centered lug mount design, with weights starting at 4.94 pounds. This caliper series has been structurally designed for high clamping efficiency and low deflection in a body width compatible with all wide 5 and 5 x 5 style hubs. It is a direct replacement for all other Superlite style calipers.



Black

The **SL4** series bodies are the products of FEA solid modeling and stress analysis technology. A reinforced radial transition between the piston housing body and the solid bridge is combined with a full body length reinforcement rib to give this caliper the highest resistance to deflection and separation under load of any Superlite style caliper available. Four high strength steel bridge bolts and a fifth center bridge bolt further add to the superior clamping efficiency while providing easy access to the 7420 style pads.

All **SL4** series calipers use a big differential bore four-piston design. The 1.88" / 1.75" piston sizes provide the largest effective piston clamping area of any model in the Superlite series. The differential bore pattern uses the pressure variance between the bore sizes to compensate for the natural temperature changes cross the face of the pad and the natural tendencies for the pad to "self load" on the leading edge. The split balance of the pad loading promotes even pad wear in the higher temperature applications. Standard **SL4** models use one piece stainless steel pistons for their low heat transfer properties and their high resistance to corrosion. For the ultimate protection in extreme sustained high heat competition, **SL4/ST** models are equipped with Wilwood's exclusive **Thermlock®** pistons. This multi-part piston assembly provides a highly effective thermal barrier that reduces heat transfer from the pads to the fluid, seals, and caliper body by as much as 30%. Seal life and fluid performance is increased proportionately. High temperature square faced seals provide the largest possible sealing surface area with controlled piston retraction on release.

Every **SL4** and **SL4/ST** caliper incorporates new and adapted performance features from other Wilwood designs. Each caliper is equipped with replaceable SRS stainless steel bridge wear plates. SRS plates eliminate the bridge wear caused by pad gouging to extend the service life of the caliper. The spring-loaded action of the SRS plates eliminates pad rattle and dampens the vibration harmonics that contribute to pad squeal. The bodies are machined with recesses to protect the fluid crossover tubes and bleed screws. The fluid tubes are dampen mounted and two piece bleed screw assemblies assure reliability in harsh conditions and round out the total performance package. The full range of Wilwood brake pad compounds is available in the 7420 type pads to match the brake response and heat range of any competition application.

SUPERLITE 4/ST WITH THERMLOCK® PISTONS CALIPER ORDERING INFORMATION:⁽¹⁾

BORE SIZE	DISC WIDTH	FRONT MOUNT PART NO.		REAR MOUNT PART NO.	
		RH	LH	RH	LH
1.88 / 1.75"	1.25" 31,8 mm	120-7570-FS	120-7571-FS	120-7570-RS	120-7571-RS
47,8 / 44,5 mm					

SUPERLITE 4/ST WITH STAINLESS STEEL PISTONS CALIPER ORDERING INFORMATION:⁽¹⁾

BORE SIZE	DISC WIDTH	FRONT MOUNT PART NO.		REAR MOUNT PART NO.	
		RH	LH	RH	LH
1.88 / 1.75"	1.25" 31,8 mm	120-7568-FS	120-7569-FS	120-7568-RS	120-7569-RS
47,8 / 44,5 mm					

NOTES: (1) REFERENCE FRONT OF MANUAL FOR GENERAL ORDERING INFORMATION

WARNING: The user or installer of any product from this catalog must determine its suitability for their intended purpose or application



BILLET SUPERLITE 4 CALIPER, MOUNTING DIMENSIONS:

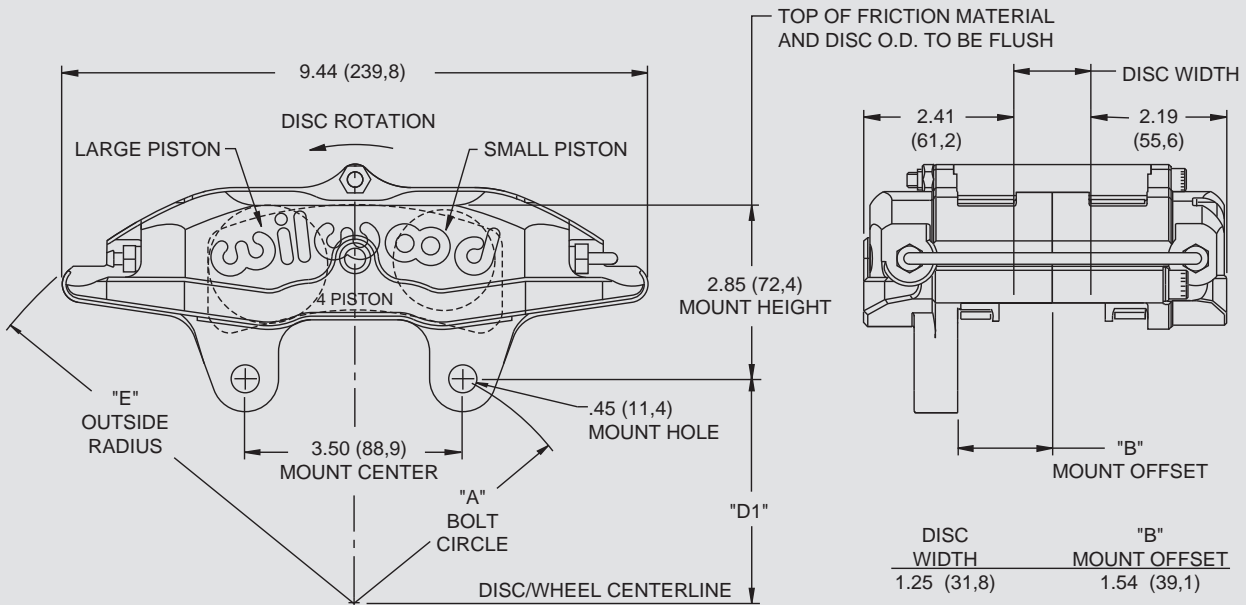

DIMENSION "D1" =
(DISC DIAMETER/2) - 2.85 (72,4)

NOTE: RIGHT HAND REAR MOUNT CALIPER SHOWN.
LEFT HAND CALIPER HAS BLEED SCREW
AND CROSSOVER TUBE REVERSED.

INLET FITTING: 1/8-27 NPT

DISC DIAMETER	"A" BOLT CIRCLE RADIUS	"E" OUTSIDE RADIUS
11.75 (298,5)	3.49 (88,6)	6.65 (168,9)
12.19 (309,6)	3.69 (93,7)	6.81 (173,0)
12.72 (323,1)	3.92 (99,6)	7.01 (178,0)
12.88 (327,2)	3.99 (101,3)	7.08 (179,8)
13.00 (330,2)	4.05 (102,9)	7.14 (181,4)

SUPERLITE 4 BRAKE PAD TYPE 7420 - PAD VOLUME = 4.9 CU. IN.:

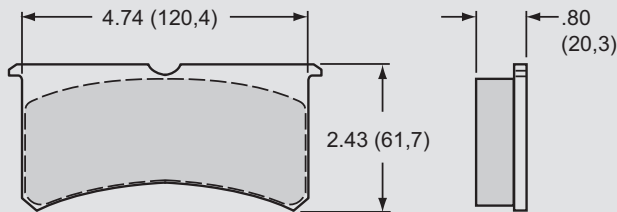

AXLE SET P/N	PAD TYPE / COMPOUND
15A - 5938K	7420 A PolyMatrix
15B - 5939K	7420 B PolyMatrix
15C - 6853K	7420 C PolyMatrix
15E - 6084K	7420 E PolyMatrix
15H - 8114K	7420 H PolyMatrix
15Q - 6829K	7420 Q PolyMatrix
150 - 8854K	7420 10 BP-10 Smart Pad
150 - 9416K	7420 20 BP-20 Smart Pad
150 - 9864K	7420 30 BP-30 Smart Pad
150 - 8323K	7420 SM For Titanium Rotor

SERVICE PARTS ORDERING INFORMATION:

CALIPER PART NO.	PISTON	SQ RING KIT (4 PK)	BLEED SCREW KIT (4 PK)	CROSSOVER TUBE KIT (4 PK)	SELF-BLEED TUBE (EA)	BRIDGE BOLT KIT	BRIDGE WEAR PLATE (EA)
120-7568	200-7522 (1.88") 200-7532 (1.75")	130-2427	220-6069	190-5975	190-8310	230-5978	300-5922 (R/H) 300-5923 (L/H)
120-7569	200-7522 (1.88") 200-7532 (1.75")	130-2427	220-6069	190-5975	190-8310	230-5978	300-5922 (R/H) 300-5923 (L/H)
120-7570	200-7550 (1.88") 200-7551 (1.75")	130-2427	220-6069	190-5975	190-8310	230-5978	300-5922 (R/H) 300-5923 (L/H)
120-7571	200-7550 (1.88") 200-7551 (1.75")	130-2427	220-6069	190-5975	190-8310	230-5978	300-5922 (R/H) 300-5923 (L/H)