



BILLET DYNAPRO LUG MOUNT CALIPER

Caliper Highlights:

The **DynaPro Lug Mount (DP)** forged billet caliper represents the newest generation of calipers available as an upgrade or replacement for applications previously using the long-standing Dynalite model series. **DP** calipers combine pure race technology with several new exclusive Wilwood performance enhancements. A sleek profile with superior strength and a fully detail machined finish provide the performance and looks for competition or show.



Black Red

The strength of the **DynaPro** is a combination of process and design. The **DynaPro** is stress-flow forged from premium grade billet. Stress-flow forging realigns the grain structure of the metal within the contour of the body design. This process produces a part with superior strength over parts simply machined from straight grained blocks of billet. The FEA generated body design incorporates a highly fortified radial transition that eliminates steps and shoulders between the piston housings and the bridges. Incorporating a radius in this critical area substantially increases resistance to deflection and caliper body separation under load. Structural deflection and volume displacement testing have proven the efficiency of this innovative design. Reductions in overall deflection, and the subsequent decreases in fluid volume displacement, translate to increased clamping efficiency with less pedal travel. The bottom line is a firm, responsive pedal with outstanding stopping power.

The **DynaPro** is loaded with other enhancements for performance and wider application. The calipers feature Quick-E-Clip pad retainers that support a 7812 type brake pad from the top. Not only does it allow for fast pad service without caliper removal, the bottom pad supports have been removed to create a slimmer profile that can be more easily fitted into tight clearance applications.

Heavy wall stainless steel pistons are used to resist corrosion and slow the heat transfer from the pads. The heavy wall sectional thickness also provides additional strength against backside deflection to provide a firm pedal feel and efficient clamping, even at the high pressures generated by power boost systems.

For additional strength, all **DP** calipers can be fitted with a center bridge bolt kit to provide even greater resistance against body separation under high load. Center bridge bolts are included with all side inlet "SI" models and available as an upgrade option on all other models.

Each **DynaPro** is also fitted with Wilwood exclusive SRS bridge plates. SRS plates eliminate the bridge wear caused by pad gouging to extend the service life of the caliper body. The spring-loading action of the SRS plates also eliminates pad rattle and dampens the vibration harmonics that contribute to squeal during engagement. The package is completed with internal fluid passages and four corner bleed screws that allow mounting in any front, rear, left, or right side position.

CALIPER ORDERING INFORMATION:⁽¹⁾

BORE SIZE		DISC WIDTH		PART NUMBER ⁽²⁾
1.75"	44,5 mm	1.25"	31,8 mm	120-9691
1.75"	44,5 mm	1.25"	31,8 mm	120-9691-SI
1.75"	44,5 mm	1.00"	25,4 mm	120-9692
1.75"	44,5 mm	.81"	20,6 mm	120-9693
1.75"	44,5 mm	.81"	20,6 mm	120-9693-SI
1.75"	44,5 mm	.50"	12,7 mm	120-9694
1.75"	44,5 mm	.38"	9,7 mm	120-9695
1.75"	44,5 mm	.38"	9,7 mm	120-9695-SI
1.38"	35,1 mm	1.25"	31,8 mm	120-9701
1.38"	35,1 mm	1.25"	31,8 mm	120-9701-SI
1.38"	35,1 mm	1.00"	25,4 mm	120-9702
1.38"	35,1 mm	.81"	20,6 mm	120-9703
1.38"	35,1 mm	.81"	20,6 mm	120-9703-SI
1.38"	35,1 mm	.50"	12,7 mm	120-9704
1.38"	35,1 mm	.38"	9,7 mm	120-9705
1.38"	35,1 mm	.38"	9,7 mm	120-9705-SI
1.00"	25,4 mm	.81"	20,6 mm	120-9706 ⁽³⁾

NOTES: (1) REFERENCE FRONT OF MANUAL FOR GENERAL ORDERING INFORMATION

(2) BRIDGE BOLT KIT OPTIONAL, EXCEPT ON -SI (SIDE INLET) WHERE IT IS STANDARD

(3) AVAILABLE RED, ADD "RD" TO END OF PART NUMBER WHEN ORDERING

WARNING: The user or installer of any product from this catalog must determine its suitability for their intended purpose or application



DYNAPRO LUG MOUNT CALIPER, MOUNTING DIMENSIONS:

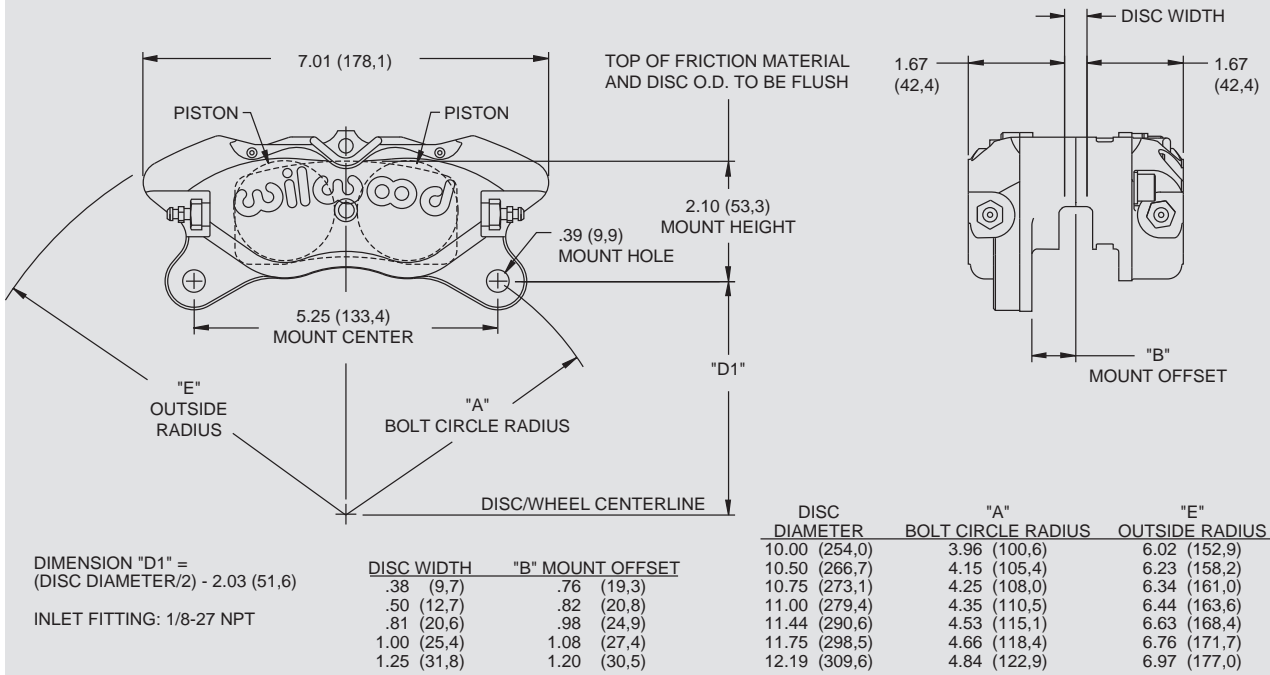

DYNAPRO BRAKE PAD TYPE 7812 - PAD VOLUME = 2.1 CU. IN.:

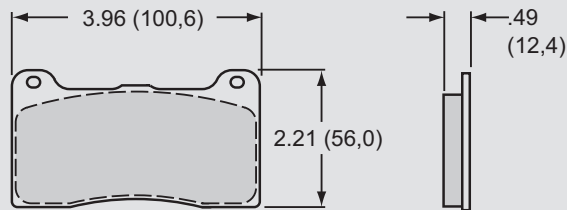

AXLE SET P/N	PAD TYPE / COMPOUND
15A - 9835K	7812 A PolyMatrix
15B - 9836K	7812 B PolyMatrix
15E - 9837K	7812 E PolyMatrix
15Q - 10385K	7812 Q PolyMatrix
150 - 9136K	7812 10 BP-10 Smart Pad
150 - 9418K	7812 20 BP-20 Smart Pad
150 - 10020K	7812 CMFor Titanium Rotor

SERVICE PARTS ORDERING INFORMATION:

CALIPER PART NO.	PISTON	SQ RING (4 PK)	BLEED SCREW KIT (4 PK)	BODY SEAL (EA)	BRIDGE WEAR PLATE (EA)	PAD RETAINER CLIP PIN (EA)	BRIDGE BOLT KIT (EA)
120-9691	200-7528 (1.75")	130-2655	220-0627	210-2582	300-5875	300-9638	230-10119
120-9692	200-7528 (1.75")	130-2655	220-0627	210-2582	300-5875	300-9637	—
120-9693	200-7528 (1.75")	130-2655	220-0627	210-2582	300-5875	300-9636	230-10118
120-9694	200-7528 (1.75")	130-2655	220-0627	210-2582	300-5875	300-9635	—
120-9695	200-7528 (1.75")	130-2655	220-0627	210-2582	300-5875	300-9634	230-10117
120-9701	200-7518 (1.38")	130-2658	220-0627	210-2582	300-5875	300-9638	230-10119
120-9702	200-7518 (1.38")	130-2658	220-0627	210-2582	300-5875	300-9637	—
120-9703	200-7518 (1.38")	130-2658	220-0627	210-2582	300-5875	300-9636	230-10118
120-9704	200-7518 (1.38")	130-2658	220-0627	210-2582	300-5875	300-9635	—
120-9705	200-7518 (1.38")	130-2658	220-0627	210-2582	300-5875	300-9634	230-10117
120-9706	200-6979 (1.00")	130-4320	220-0627	210-2582	300-5875	300-9636	230-10118