

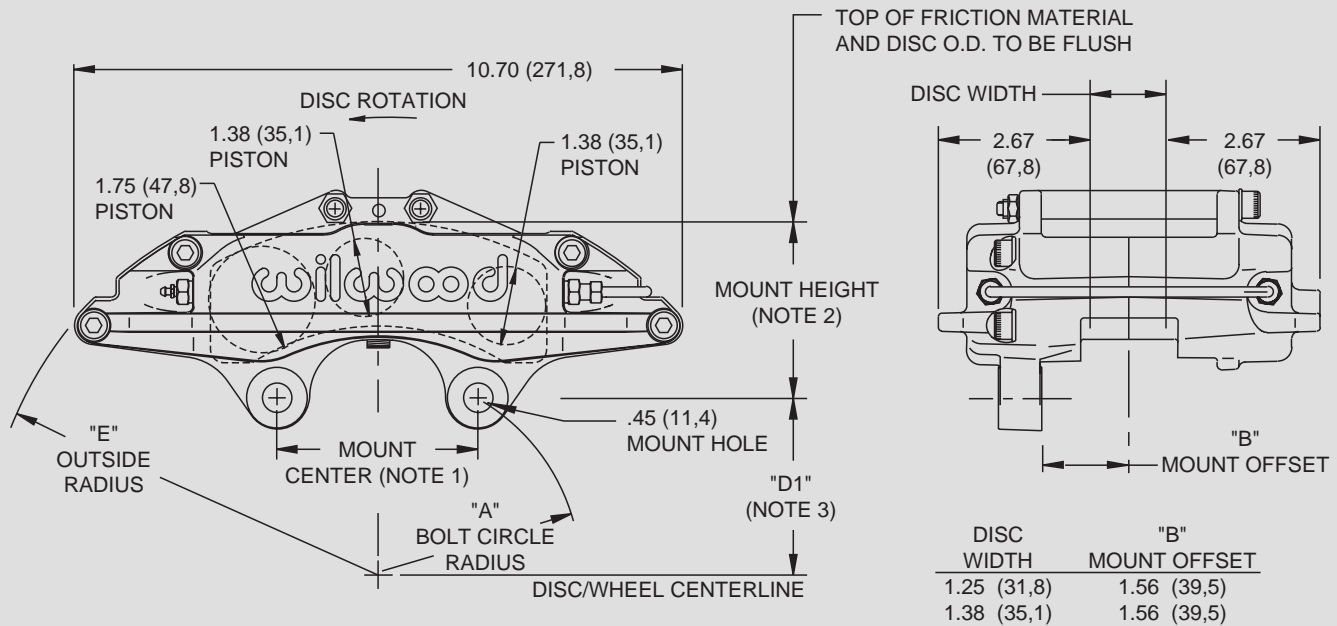

**GN III CALIPER, MOUNTING DIMENSIONS:**



NOTE 1: MOUNT CENTERS 3.50" (88,9) OR 6.00" (152,4)

NOTE 2: 3.07" (77,9) FOR 3.50" MOUNT CENTER MODELS  
3.11" (79,0) FOR 6.00" MOUNT CENTER MODELS

NOTE 3: 3.50" MOUNT "D1" = (DISC DIAMETER/2) - 3.07 (77,9)  
6.00" MOUNT "D1" = (DISC DIAMETER/2) - 3.11 (79,0)

NOTE 4: RIGHT HAND, REAR MOUNT CALIPER SHOWN  
INLET FITTING: 1/8-27 NPT

DISC DIAMETER	"A" BOLT CIRCLE RADIUS 3.50" MOUNT	"A" BOLT CIRCLE RADIUS 6.00" MOUNT	"E" OUTSIDE RADIUS
12.19 (309,6)	3.50 (88,9)	4.23 (107,4)	6.92 (175,8)
12.72 (323,1)		4.42 (112,3)	7.10 (180,3)
13.00 (330,2)		4.53 (115,1)	7.19 (182,6)

**GN III BRAKE PAD TYPE 7520 - PAD VOLUME = 6.9 CU. IN.:**

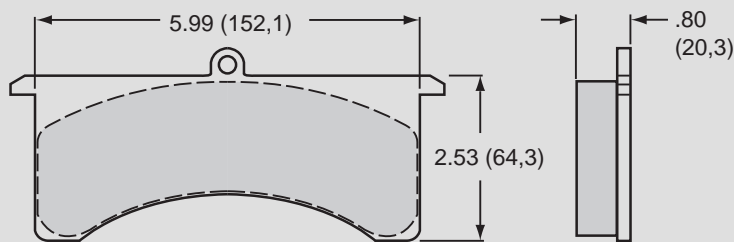

AXLE SET P/N	PAD TYPE / COMPOUND
15A - 5736K	7520 A PolyMatrix
15B - 3993K	7520 B PolyMatrix
15E - 6101K	7520 E PolyMatrix
15Q - 6879K	7520 Q PolyMatrix
150 - 9425K	7520 10 BP-10 Smart Pad
150 - 9417K	7520 20 BP-20 Smart Pad

**SERVICE PARTS ORDERING INFORMATION:**

CALIPER PART NO.	PISTON	SQ RING KIT (6 PK)	BLEED SCREW KIT (4 PK)	CROSSOVER TUBE KIT (4 PK)	SELF-BLEED TUBE (EA)	BRIDGE BOLT KIT	BRIDGE WEAR PLATE (EA)	COTTER PINS (10 PK)
120-3030	200-7516 (1.38") 200-7531 (1.75")	130-3084	220-0627	190-3664	190-3615	230-3029	300-3053	180-0053
120-3031	200-7516 (1.38") 200-7531 (1.75")	130-3084	220-0627	190-3664	190-3615	230-3029	300-3053	180-0053
120-6478	200-7516 (1.38") 200-7531 (1.75")	130-3084	220-0627	190-3664	190-3615	230-3029	300-3053	180-0053
120-6479	200-7516 (1.38") 200-7531 (1.75")	130-3084	220-0627	190-3664	190-3615	230-3029	300-3053	180-0053