



# FIXED MOUNT ROTOR HATS

## GT Series Fixed Mount Rotor Hats

GT Series hats are precision machined from premium aluminum alloys for high strength and attention to minimized weight. Hats in this category feature threaded rotor mount holes for use with standard through-hole mount rotors. Threaded hole hats may also be used with T-Nuts or bobbins designed for use with specially machined slotted hole dynamic mount rotors. When used in conjunction with matched Wilwood rotor hardware kits, GT hats provide solid, reliable performance in the most demanding conditions.

### SHALLOW OFFSET HATS:

**Shallow Offset Hats** are for narrow space applications with offsets often less than 1.00". They are available for most rotor bolt patterns in a variety of four and five lug wheel patterns.

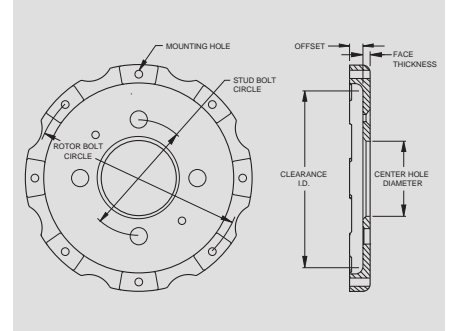

### STRAIGHT BELL HATS:

**Straight Bell Hats** are most often used with 11.75" to 13.00" diameter rotors with 6.75" or 7.00" rotor mount bolt circle rotors on stock car front hubs and rear axles.

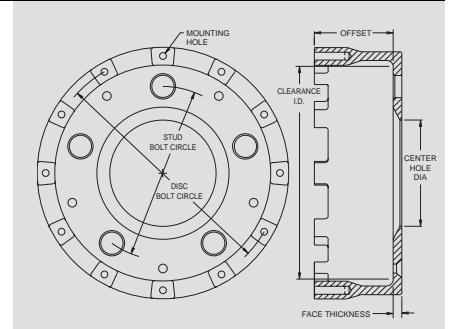

### FLARED BELL HATS:

**Flared Bell Hats** are generally used with rotor mount bolt circles of 8.38" and larger. Offsets range from 1.88" to 3.00" for rotor diameters 12.19" and up.

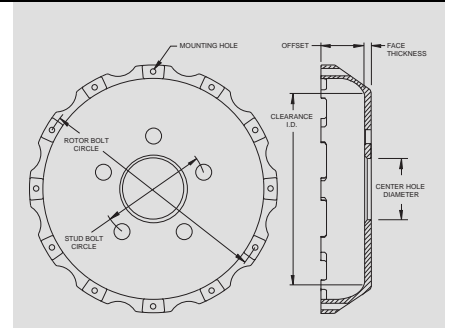

### TRUCK HATS:

**Truck Hats** feature strengthening ribs on a flared bell configuration for big rotor brake kits on truck, SUV, and 4WD axles with either 6 or 8 lug configurations.

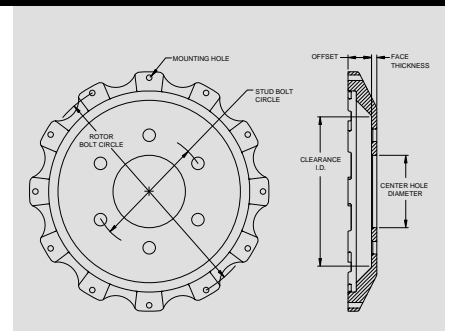

**WARNING:** The user or installer of any product from this catalog must determine its suitability for their intended purpose or application