



GT SERIES DYNAMIC MOUNT ROTOR HATS:

GT Series Dynamic Mount Rotor Hats are engineered to withstand the rigors and demands of extreme motorsports competition. Each hat is precision machined from premium grade aluminum offering high strength with low unsprung and rotating weight. Wilwood T-nuts float within the hat and provide true dynamic mounting of a standard through-hole mount rotor. The wide load bearing load surface of the T-nut and the straight through-hole



mount rotors provide the most durable and accurate method of isolating potential pad engagement harmonics and the in-service thermal variations that occur between the hat and the rotor.

GT Series Dynamic Mount Hats are available in a variety of configurations for use with racing hubs, flanged axles, and several OE applications. Straight bell hats are used for the 6.75" and 7.00" rotor mount patterns. Hats for the larger diameter rotor mount patterns will be the flared bell design. Use the charts below to match the rotor mount circle, lug pattern, offset, and the other dimensions necessary for each application.

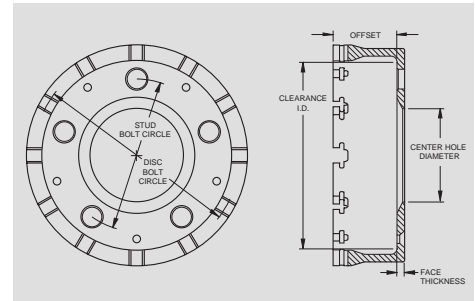
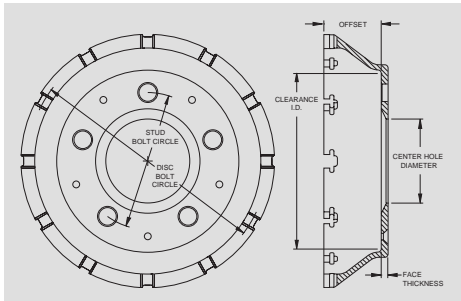

ORDERING INFORMATION:

ROTOR BOLT CIRCLE	WHEEL LUG PATTERN	HAT OFFSET	STUD HOLE DIAMETER	CENTER HOLE I.D.	FACE THICKNESS	CLEARANCE I.D.	MOUNT HOLE	HAT PART NUMBER	BOLT & T-NUT KIT NUMBER	NOTES
12 x 8.75"	5 x 5.00"	2.12"	.64"	3.06"	.25"	6.40"	T-SLOT	170-6583	230-6656	(1)
12 x 8.75"	5 x 5.00"	1.88"	.64"	3.06"	.25"	6.40"	T-SLOT	170-7652	230-6656	(1)
12 x 8.38"	5 x 5.00"	2.12"	.64"	3.06"	.25"	6.40"	T-SLOT	170-6518	230-6656	(1)
12 x 8.38"	5 x 5.00"	1.88"	.64"	3.06"	.25"	6.40"	T-SLOT	170-7650	230-6656	(1)
12 x 7.00"	5 x 5.00"	2.12"	.64"	3.06"	.25"	6.40"	T-SLOT	170-6580	230-6656	(1)
12 x 7.00"	5 x 5.00"	1.88"	.64"	3.06"	.25"	6.40"	T-SLOT	170-7651	230-6656	(1)
12 x 6.75"	5 x 5.00"	2.12"	.64"	3.06"	.25"	6.12"	T-SLOT	170-6517	230-6656	(1)
12 x 6.75"	5 x 5.00"	1.88"	.64"	3.06"	.25"	6.12"	T-SLOT	170-7400	230-6656	(1)
12 x 6.75"	5 x 5.00"	1.74"	.64"	3.06"	.25"	6.12"	T-SLOT	170-7399	230-6656	(1)
8 x 8.50"	5 x 5.00"	2.12"	.64"	3.06"	.25"	6.40"	T-SLOT	170-6582	230-6709	(1)
8 x 7.00"	5 x 5.00"	2.12"	.64"	3.06"	.25"	6.64"	T-SLOT	170-6581	230-6710	(1)
8 x 7.00"	5 x 4.75/5.00"	1.96"	.70"	3.06"	.25"	6.40"	T-SLOT	170-7662	230-7666	(2)
8 x 7.00"	5 x 4.50/4.75/5.00"	1.96"	.52"	3.06"	.25"	6.40"	T-SLOT	170-7661	230-7666	(2)
8 x 7.00"	5 x 4.50/4.75/5.00"	1.41"	.52"	3.06"	.25"	6.32"	T-SLOT	170-7694	230-7666	(2)

NOTES:

- (1) THIS HAT IS DRILLED AND COUNTERSUNK TO ACCOMMODATE HAT TO HUB ANCHORING SCREWS. SCREW KIT P/N 230-2482 CONTAINS FIVE (5) GRADE 8 1/4-28 X 1.00" COUNTERSUNK FLAT HEAD HEX DRIVE SCREWS AND SHOULD BE ORDERED IN ADDITION TO THE HAT
- (2) ROTOR BOLT AND T-NUT KIT P/N 230-7666 INCLUDES A SHORT PROFILE HEX HEAD BOLT THAT PROVIDES ADDITIONAL CLEARANCE BETWEEN THE BOLT HEAD AND THE CALIPER MOUNT BRACKET USED ON WILWOOD DYNAMIC MOUNT REAR DRAG KITS. THESE HATS ARE ALSO COMPATIBLE WITH BOLT AND T-NUT KIT P/N 230-6710 ON OTHER APPLICATIONS WHERE ADDITIONAL CLEARANCE EXISTS BETWEEN THE ROTOR BOLT HEAD AND THE CALIPER MOUNTING HARDWARE