



INTEGRA 6R RADIAL MOUNT CALIPER

Caliper Highlights:

Wilwood's six piston **Integra 6R** caliper utilizes sophisticated Finite Element Analysis, Stress Simulation and Heat Management programs to provide a powerhouse of stopping performance weighing just 5.50 pounds. The **Integra 6R** caliper employs our proven exclusive piston stagger pattern resulting in unmatched caliper rigidity and balanced pad load characteristics; brake pad distortion and taper is virtually eliminated. The fully heat shielded design provides phenomenal heat protection for a consistent, responsive pedal throughout the longest races.



■ Black

Three different pad and rotor combinations are utilized with this caliper depending on race requirements: short track/road course, intermediate track and super speedways or qualifying. With the **Integra 6R** caliper, brake performance is maximized while maintaining the lowest possible unsprung weight. All Wilwood **Integra** calipers come standard with **Thermlock® T2** insulated short track pistons for maximum heat protection.

We also offer a lightweight mounting bracket, either aluminum or steel from 7.09" (180,0) radial to 5.25" (133,4) **GT** lug mount pattern. Self bleed lines are also available for these calipers.

Thermlock T2 Short Track Piston:

Wilwood's **Thermlock® T2** pistons incorporate a stainless steel shield and coated aluminum shell configuration to provide a highly efficient thermal barrier between the brake pads and the caliper body, seals, and fluid. Lower operating temperatures eliminate seal crystallization and localized fluid boiling while providing longer caliper service life through decreased distortion in the caliper body and piston bores. **Thermlock® T2** pistons are standard equipment in all **Integra** calipers.

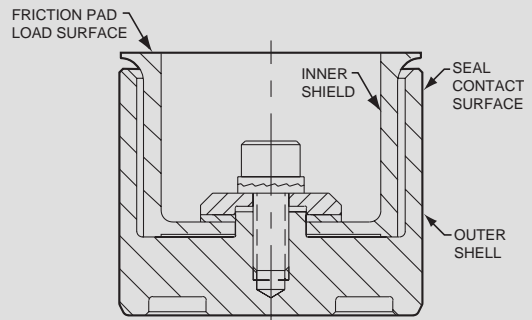

Thermlock T2 Piston Cross-Section

- 1.62" (41,1 mm) Diameter - Order P/N: 200-7398
- 1.25" (31,8 mm) Diameter - Order P/N: 200-7402

Caliper Ordering Information:⁽¹⁾

Bore Size	Disc Width	Front Mount Part No.		Rear Mount Part No.	
		RH	LH	RH	LH
1.62 / 1.25 / 1.25" 41,1 / 31,8 / 31,8 mm	1.38 / 1.31 / 1.25" 35,1 / 33,3 / 31,8 mm	120-5690-FS	120-5691-FS	120-5690-RS	120-5691-RS

Caliper Mounting Bracket Kit 7.09" (180,0) Radial to 5.25" (133,4) GT Lug	
Aluminum Bracket	P/N: 250-5687
Steel Bracket	P/N: 250-7423

NOTES: (1) REFERENCE FRONT OF MANUAL FOR GENERAL ORDERING INFORMATION (FS = FRONT SIDE MOUNT, RS = REAR SIDE MOUNT)

WARNING: The user or installer of any product from this catalog must determine its suitability for their intended purpose or application