

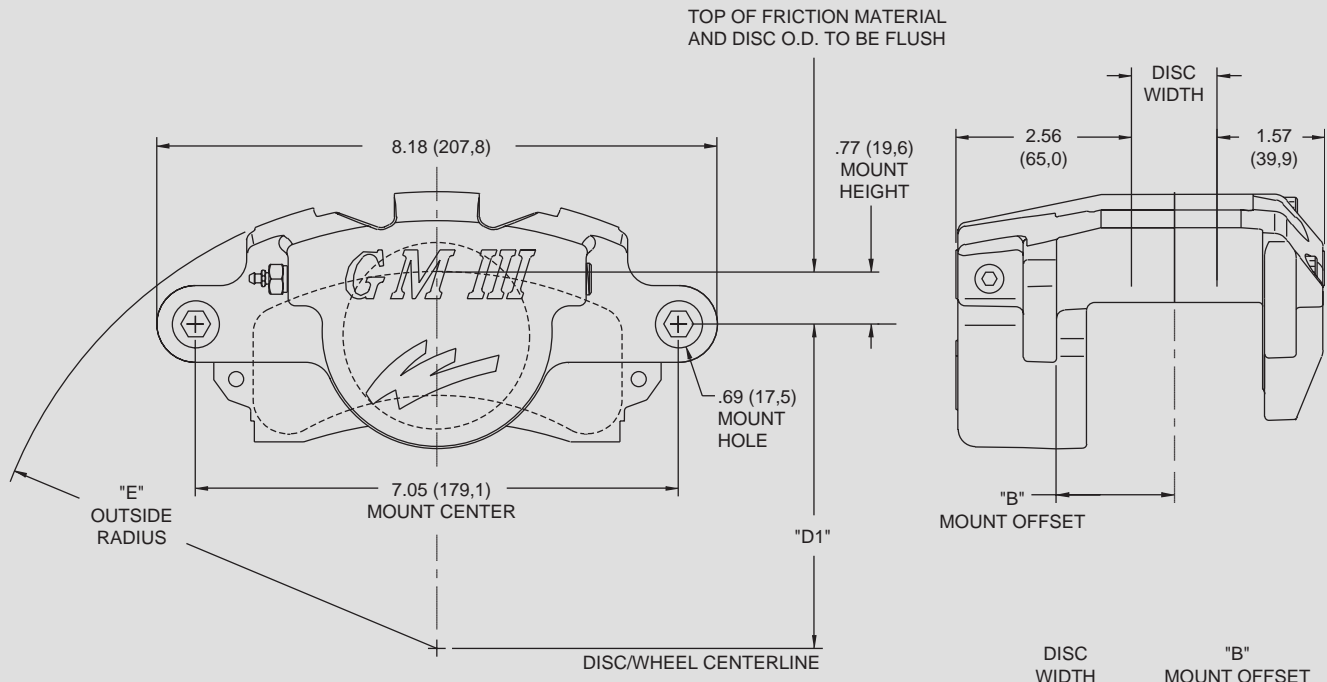

**GM III CALIPER, MOUNTING DIMENSIONS:**



DIMENSION "D1" = (DISC DIAMETER/2) - .77 (19,6)  
 CALIPER MOVES INWARD AS PAD WEARS, .35 (8,9) MAX

NOTE: RIGHT HAND CALIPER SHOWN, LEFT HAND HAS BLEED SCREW REVERSED

INLET FITTING: 1/8-27 NPT

DISC WIDTH	"B" MOUNT OFFSET
.81 (20,6)	1.50 (38,1)
1.00 (25,4)	1.72 (43,7)
1.25 (31,8)	1.72 (43,7)

DISC DIAMETER	"E" OUTSIDE RADIUS
11.00 (279,4)	6.69 (169,9)
11.75 (298,5)	7.04 (178,8)

**GM III BRAKE PAD TYPE D52 - PAD VOLUME "INNER" = 3.9 CU. IN. / PAD VOLUME "OUTER" = 3.8 CU. IN.:**

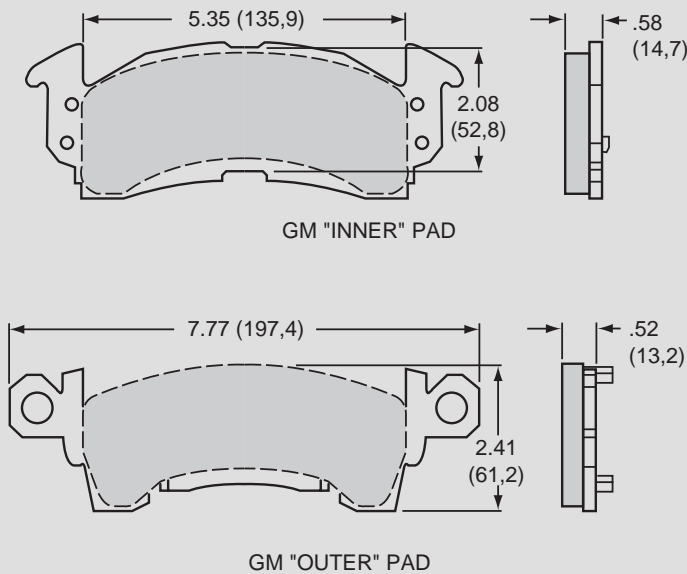

AXLE SET P/N	PAD TYPE / COMPOUND
15A - 5737K	D52 A PolyMatrix
15B - 3994K	D52 B PolyMatrix
15C - 4419K	D52 C PolyMatrix
15E - 6102K	D52 E PolyMatrix
15H - 8232K	D52 H PolyMatrix
15Q - 6830K	D52 Q PolyMatrix
150 - 8939K	D52 10 BP-10 Smart Pad
150 - 9421K	D52 20 BP-20 Smart Pad
150 - 9866K	D52 30 BP-30 Smart Pad