

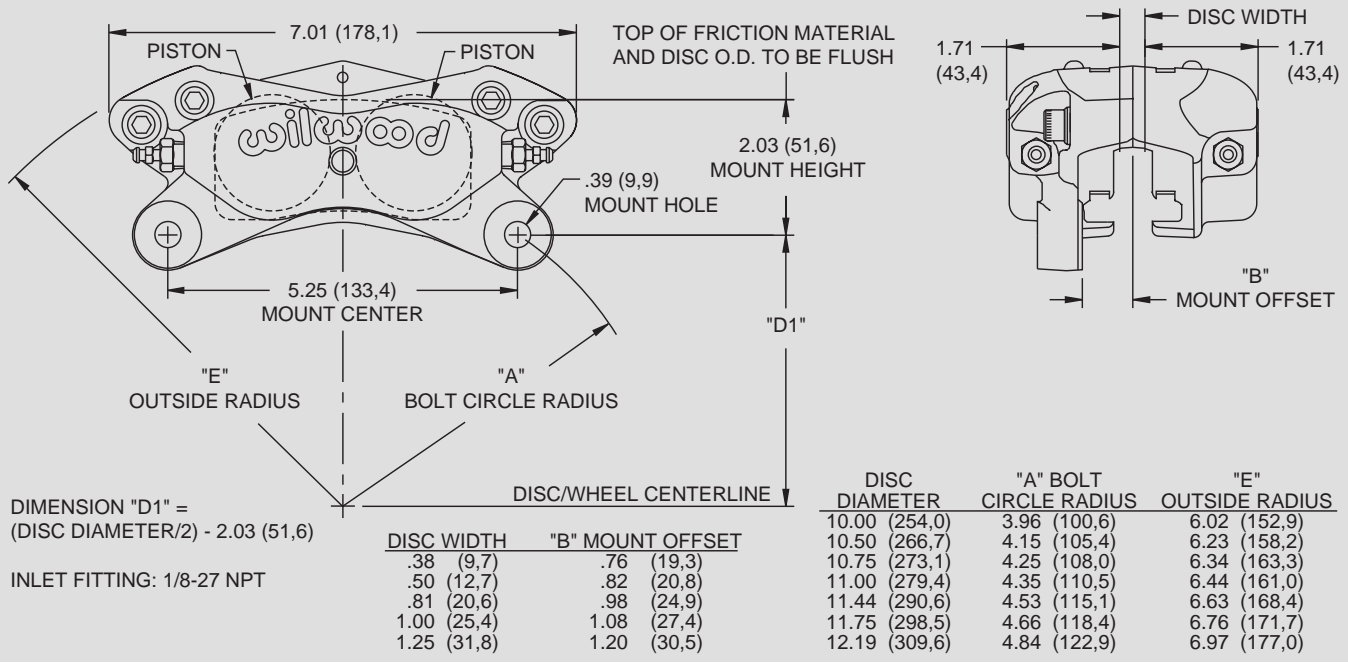

FORGED DYNALITE CALIPER, MOUNTING DIMENSIONS:

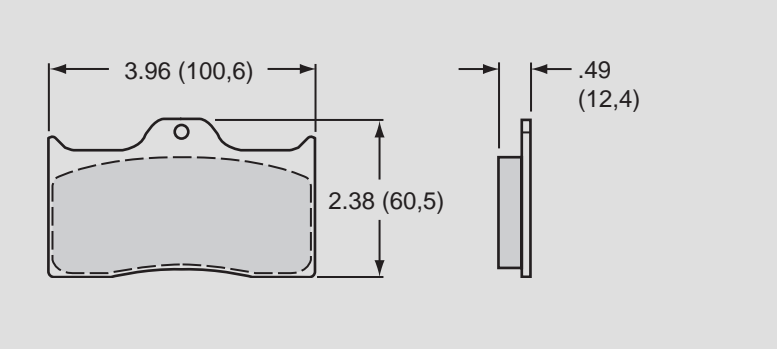

DYNALITE BRAKE PAD TYPE 7112 - PAD VOLUME = 2.1 CU. IN.:



AXLE SET P/N	PAD TYPE / COMPOUND
15A - 5734K	7112 A PolyMatrix
15B - 3991K	7112 B PolyMatrix
15C - 4415K	7112 C PolyMatrix
15E - 6096K	7112 E PolyMatrix
15H - 8291K	7112 H PolyMatrix
15Q - 6824K	7112 Q PolyMatrix
15T - 5911K	7112 T PolyMatrix
150 - 8850K	7112 10 BP-10 Smart Pad
150 - 9413K	7112 20 BP-20 Smart Pad
150 - 9863K	7112 30 BP-30 Smart Pad
150 - 8450K	7112 SM For Titanium Rotor

SERVICE PARTS ORDERING INFORMATION:

CALIPER PART NO.	PISTON	SQ RING KIT (4 PK)	BLEED SCREW KIT (4 PK)	BODY SEAL (EA)	BRIDGE WEAR PLATE (EA)	COTTER PIN (10 PK)
120-6789-P	200-7518 (1.38")	130-2658	220-0627	210-2582	300-5875	180-0056
120-6790-P	200-7518 (1.38")	130-2658	220-0627	210-2582	300-5875	180-0056
120-6791-P	200-7518 (1.38")	130-2658	220-0627	210-2582	300-5875	180-0055
120-6792-P	200-7518 (1.38")	130-2658	220-0627	210-2582	300-5875	180-0055
120-6793-P	200-7518 (1.38")	130-2658	220-0627	210-2582	300-5875	180-0054
120-6794-P	200-7520 (1.62")	130-4346	220-0627	210-2582	300-5875	180-0056
120-6795-P	200-7520 (1.62")	130-4346	220-0627	210-2582	300-5875	180-0056
120-6796-P	200-7520 (1.62")	130-4346	220-0627	210-2582	300-5875	180-0055
120-6797-P	200-7520 (1.62")	130-4346	220-0627	210-2582	300-5875	180-0055
120-6798-P	200-7520 (1.62")	130-4346	220-0627	210-2582	300-5875	180-0054
120-6804	200-7518 (1.38")	130-2658	220-0627	210-2582	300-5875	180-0056
120-6805	200-7518 (1.38")	130-2658	220-0627	210-2582	300-5875	180-0056
120-6806	200-7518 (1.38")	130-2658	220-0627	210-2582	300-5875	180-0055
120-6807	200-7518 (1.38")	130-2658	220-0627	210-2582	300-5875	180-0055
120-6808	200-7518 (1.38")	130-2658	220-0627	210-2582	300-5875	180-0054
120-6809	200-7520 (1.62")	130-4346	220-0627	210-2582	300-5875	180-0056
120-6810	200-7520 (1.62")	130-4346	220-0627	210-2582	300-5875	180-0056
120-6811	200-7520 (1.62")	130-4346	220-0627	210-2582	300-5875	180-0055
120-6812	200-7520 (1.62")	130-4346	220-0627	210-2582	300-5875	180-0055
120-6813	200-7520 (1.62")	130-4346	220-0627	210-2582	300-5875	180-0054
120-6814	200-7528 (1.75")	130-2655	220-0627	210-2582	300-5875	180-0056
120-6815	200-7528 (1.75")	130-2655	220-0627	210-2582	300-5875	180-0056
120-6816	200-7528 (1.75")	130-2655	220-0627	210-2582	300-5875	180-0055
120-6817	200-7528 (1.75")	130-2655	220-0627	210-2582	300-5875	180-0055
120-6818	200-7528 (1.75")	130-2655	220-0627	210-2582	300-5875	180-0054