

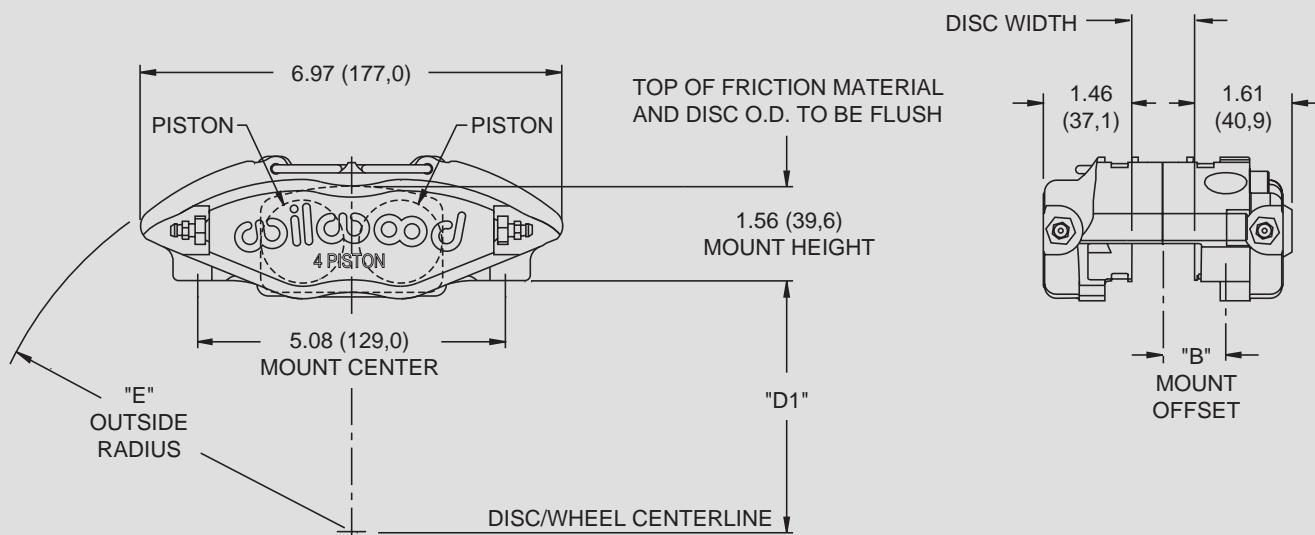

POWERLITE CALIPER, MOUNTING DIMENSIONS:



DIMENSION "D1" =
(DISC DIAMETER/2) - 1.56 (39,6)

INLET FITTING: 1/8-27 NPT

DISC WIDTH	"B" MOUNT OFFSET	DISC DIAMETER	"E" OUTSIDE RADIUS	"D1" DIMENSION
.35/.50 (8,9/12,7)	.85 (21,5)	10.25 (260,4)	5.81 (147,5)	3.57 (90,7)
.79/.85 (20,0/22,0)	1.03 (26,2)	10.50 (266,7)	5.93 (150,5)	3.69 (93,7)
		10.75 (273,0)	6.04 (153,5)	3.82 (97,0)
		11.00 (279,4)	6.16 (156,5)	3.94 (100,1)

RADIAL CALIPER TO LUG MOUNT ADAPTER BRACKET, PART NUMBER 250-8914:

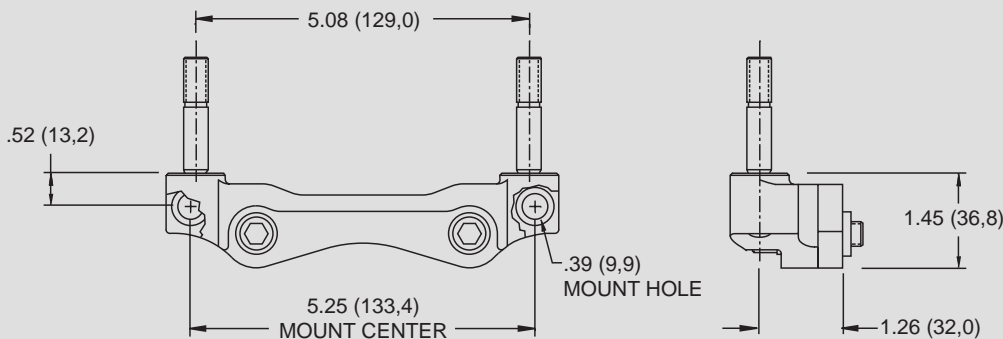

NOTE:
BRACKET KIT INCLUDES
STUDS, LOCKNUTS,
WASHERS AND
ALIGNMENT SHIMS

SERVICE PARTS ORDERING INFORMATION:

CALIPER PART NO.	PISTON	SQ RING (4 PK)	BLEED SCREW KIT (4 PK)	BODY SEAL (EA)	BRIDGE WEAR PLATE (EA)	PAD RETAINER CLIP PIN (EA)
120-8724	200-8845 (1.00")	130-4320	220-6069	210-2582	300-5875	300-8697
120-8725	200-8844 (1.25")	130-2479	220-6069	210-2582	300-5875	300-8697
120-8726	200-8843 (1.38")	130-2658	220-6069	210-2582	300-5875	300-8697
120-8727	200-8845 (1.00")	130-4320	220-6069	210-2582	300-5875	300-8697
120-8728	200-8844 (1.25")	130-2479	220-6069	210-2582	300-5875	300-8697
120-8729	200-8843 (1.38")	130-2658	220-6069	210-2582	300-5875	300-8697