

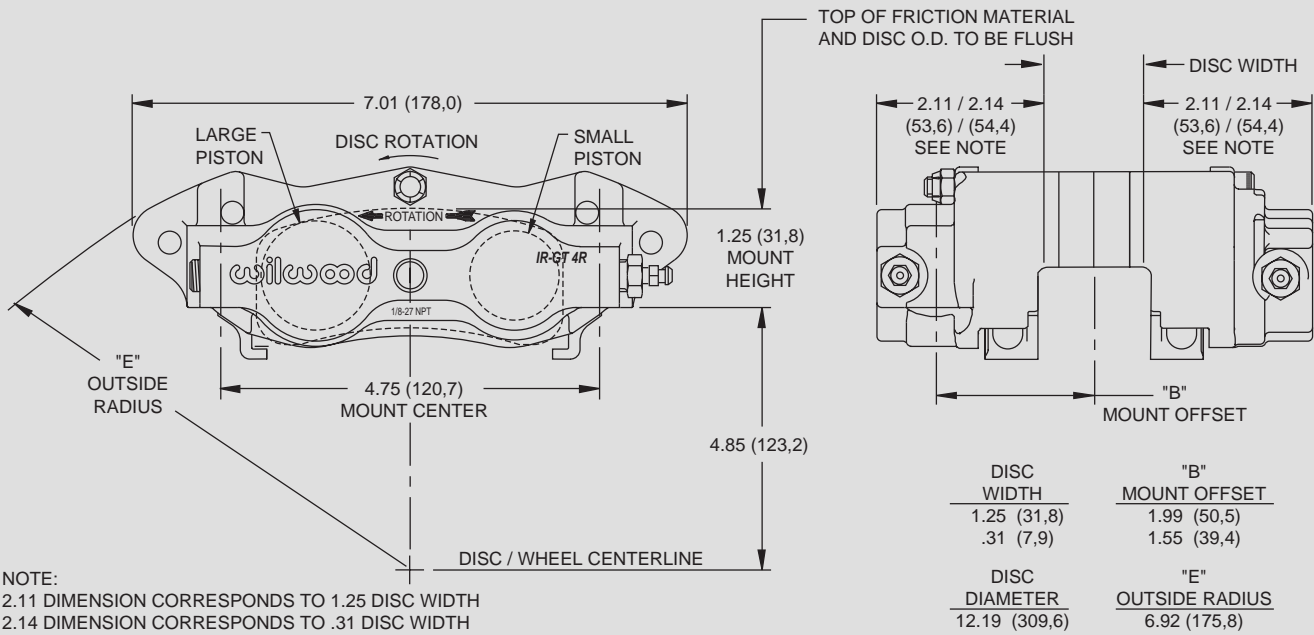

IR-GT4R RADIAL MOUNT CALIPER, MOUNTING DIMENSIONS:

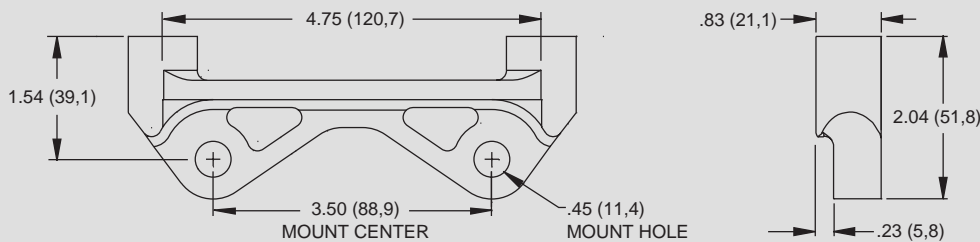

RADIAL CALIPER TO LUG MOUNT ADAPTER BRACKET, PART NUMBER 250-6625:



SERVICE PARTS ORDERING INFORMATION:

CALIPER PART NO.	PISTON	SQ RING KIT (4 PK)	BLEED SCREW KIT (4 PK)	BODY SEAL (EA)	BRIDGE WEAR PLATE (EA)
120-6604	200-7516 (1.38") 200-7513 (1.12")	130-7218	220-0627	210-2582	300-5066 (R/H) 300-5067 (L/H)
120-6605	200-7516 (1.38") 200-7513 (1.12")	130-7218	220-0627	210-2582	300-5066 (R/H) 300-5067 (L/H)
120-6606	200-4655 (1.25") 200-4657 (1.00")	130-7219	220-0627	210-2582	300-5066 (R/H) 300-5067 (L/H)
120-6607	200-4655 (1.25") 200-4657 (1.00")	130-7219	220-0627	210-2582	300-5066 (R/H) 300-5067 (L/H)