

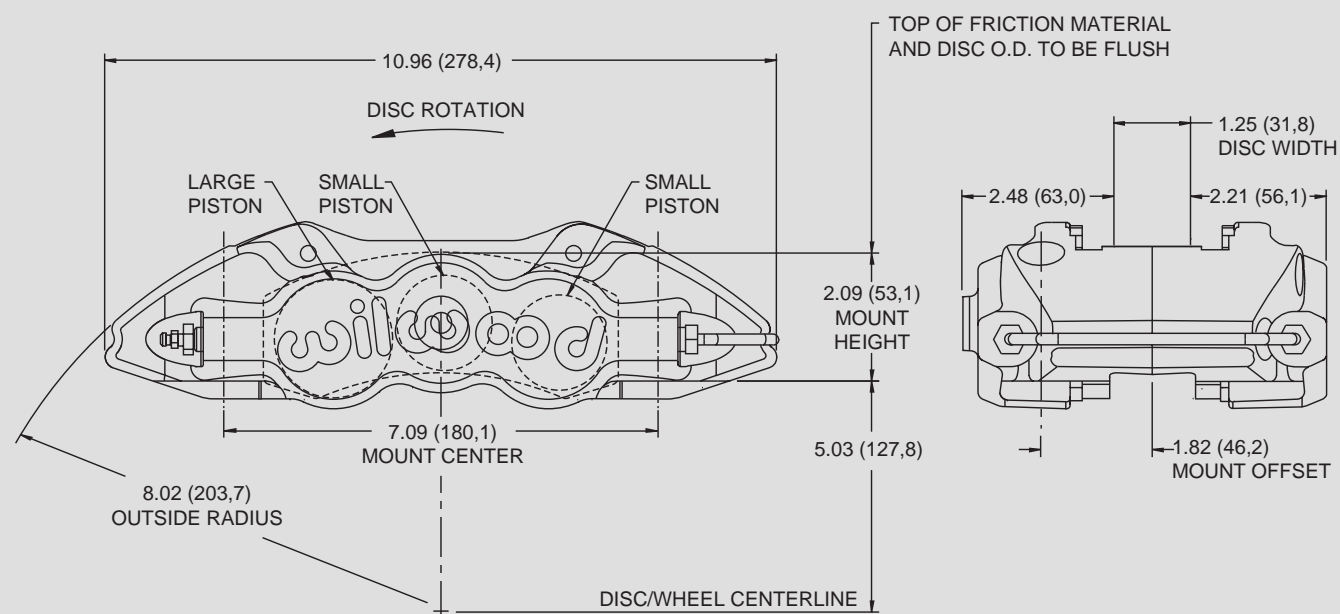

W6A CALIPER, MOUNTING DIMENSIONS:



DIMENSIONS FOR USE WITH
A 14.25 (362,0) X 1.25 (31,8) DISC

NOTE: RIGHT HAND, REAR MOUNT
CALIPER SHOWN - INLET FITTING: 1/8-27 NPT

RADIAL CALIPER ADAPTER BRACKETS:

Radial mount adapter brackets are used in Wilwood brake kits to provide a secure and precise method of attaching the W6A caliper to the factory mount bosses on the original spindle. For a list of specific available applications, consult the Wilwood Bolt-On Brake Kit catalog, or visit the kit section of our website @ www.wilwood.com.



SERVICE PARTS ORDERING INFORMATION:

CALIPER PART NO.	PISTON	SQ RING KIT (6 PK)	BLEED SCREW KIT (4 PK)	CROSSOVER TUBE KIT (2 PK)	PAD RETAINING KIT (2 PK)	BRIDGE WEAR PLATE (EA)
120-9398	200-7531 (1.75") 200-7516 (1.38")	130-3084	220-6069	190-9875	180-9874	300-5876
120-9399	200-7531 (1.75") 200-7516 (1.38")	130-3084	220-6069	190-9875	180-9874	300-5876
120-9402	200-7519 (1.62") 200-7513 (1.12")	130-5972	220-6069	190-9875	180-9874	300-5876
120-9403	200-7519 (1.62") 200-7513 (1.12")	130-5972	220-6069	190-9875	180-9874	300-5876