

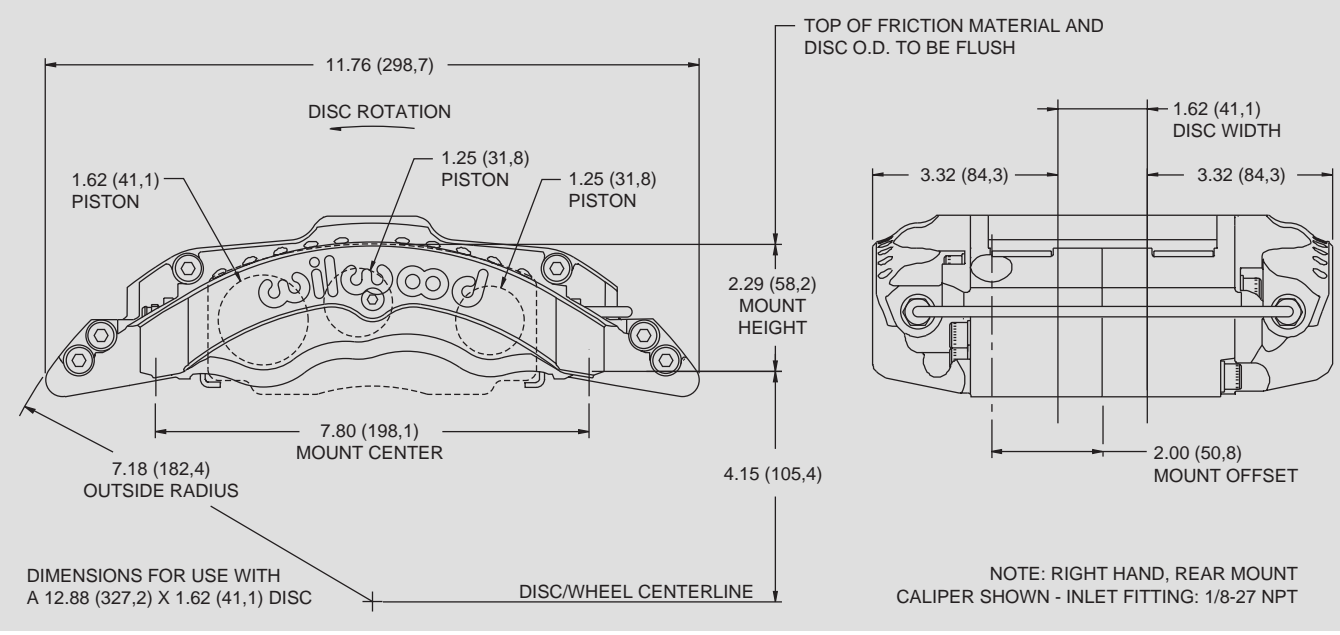

STR CALIPER, MOUNTING DIMENSIONS:

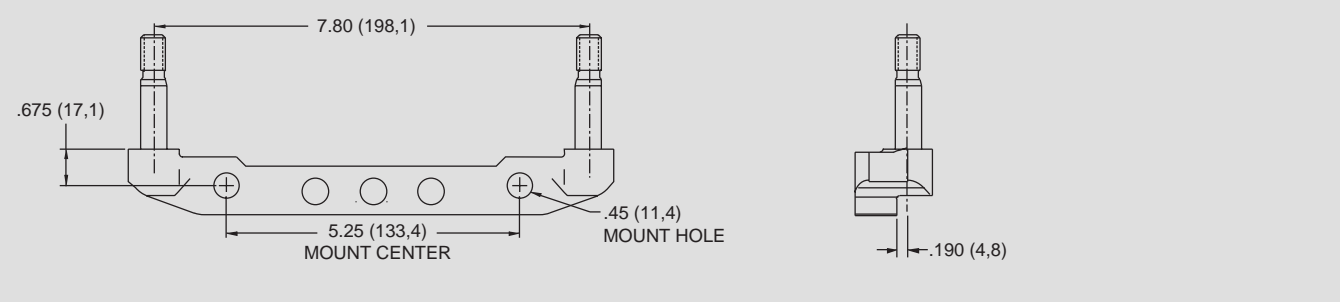

RADIAL CALIPER TO LUG MOUNT ADAPTER BRACKET, PART NUMBER 250-7426 - STEEL:



STR BRAKE PAD TYPE 9330 - PAD VOLUME = 13.2 CU. IN.:

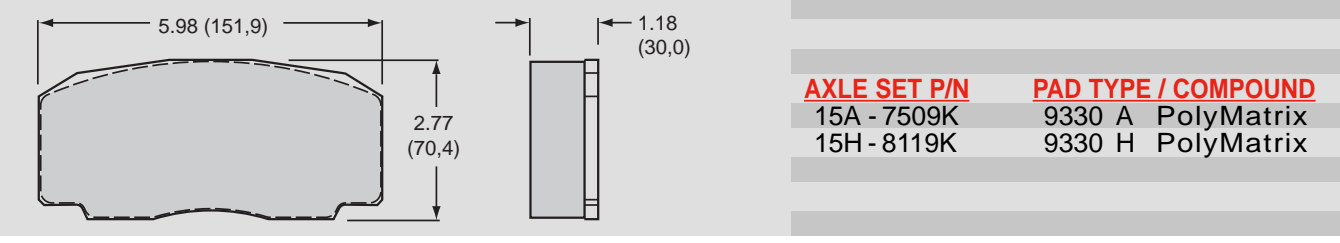

SERVICE PARTS ORDERING INFORMATION:

CALIPER PART NO.	THERMLOCK PISTON	SQ RING KIT (6 PK)	BLEED SCREW KIT (4 PK)	CROSSOVER TUBE KIT (2 PK)	SELF-BLEED TUBE (EA)	BRIDGE BAR KIT	BRIDGE WEAR PLATE (EA)	MOUNT BOLT AND SHIM KIT
120-7482	200-7402 (1.25") 200-7398 (1.62")	130-5660	220-6069	190-7547	190-7507	300-7546	300-7490	230-7031
120-7483	200-7402 (1.25") 200-7398 (1.62")	130-5660	220-6069	190-7547	190-7507	300-7546	300-7490	230-7031