



GM METRIC CALIPER

Caliper Highlights:

Wilwood's **GM Metric Caliper** is a direct replacement for the 1978 and later D154 type GM metric caliper. Weights starting at 2.92 pounds, it provides a substantial weight savings over cast iron OE calipers.

This competition caliper represents the latest refinements in caliper design and manufacturing through the use of computer based FEA solid modeling and stress simulation programs. The real strength of this caliper comes from its triple bridge configuration, and its lightness is a result of efficient design.

The triple bridge provides higher clamping efficiency through lower deflection over all twin bridge models. All load bearing and stress points are fortified to maximize strength, and all unnecessary material is removed to maximize weight reduction. The results are the strongest, lightest, and most efficient aluminum caliper in its class.

The caliper body is a precision casting using a tight grained, high density aircraft alloy. Stainless steel pistons provide improved fluid protection with high resistance to corrosion and low heat transfer. Each caliper is fully machined, assembled with high temperature seals, and tested in-house.



CALIPER ORDERING INFORMATION:⁽¹⁾

BORE SIZE		DISC WIDTH		PART NUMBER ^(2,3)
2.38"	60,4 mm	1.25"	31,8 mm	120-6427
2.38"	60,4 mm	1.00"	25,4 mm	120-7197 ⁽⁴⁾
2.38"	60,4 mm	.81"	20,6 mm	120-6426

GM METRIC CALIPER, MOUNTING DIMENSIONS:

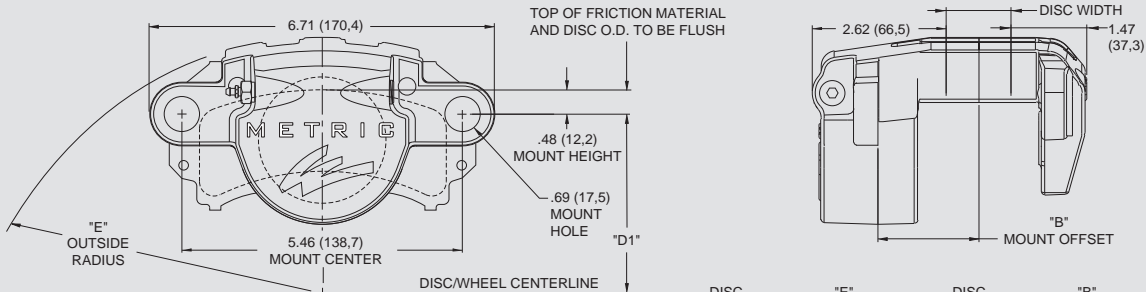

DIMENSION "D1" = (DISC DIAMETER/2) - .48 (12,2)
 CALIPER MOVES INWARD AS PAD WEARS, .35 (8,9) MAX
 NOTE: RIGHT HAND CALIPER SHOWN, LEFT HAND HAS BLEED SCREW REVERSED
 INLET FITTING: 1/8-27 NPT

DISC DIAMETER	"E" OUTSIDE RADIUS	DISC WIDTH	"B" MOUNT OFFSET
11.00 (279,4)	6.55 (166,4)	.81 (20,6)	1.74 (44,2)
11.75 (298,5)	6.90 (175,3)	1.00 (25,4)	1.84 (46,7)
		1.25 (31,8)	1.96 (49,8)

GM METRIC BRAKE PAD TYPE D154 - PAD VOLUME "INNER" = 2.7 CU. IN. / - PAD VOLUME "OUTER" = 3.2 CU. IN.:

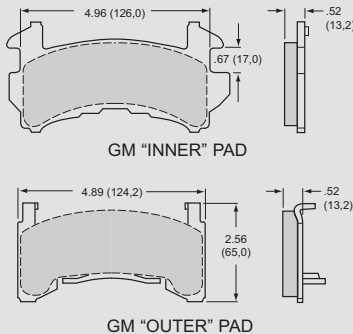

AXLE SET P/N	PAD TYPE / COMPOUND
15A - 6219K	D154 A PolyMatrix
15B - 3998K	D154 B PolyMatrix
15C - 4420K	D154 C PolyMatrix
15E - 6103K	D154 E PolyMatrix
15Q - 6831K	D154 Q PolyMatrix
150 - 8936K	D154 10 BP-10 Smart Pad
150 - 9422K	D154 20 BP-20 Smart Pad

SERVICE PARTS ORDERING INFORMATION:

CALIPER PART NO.	PISTON	O-RING KIT (4 PK)	BLEED SCREW KIT (4 PK)	SLIDE PIN KIT (4 PK)
120-6426	200-1119 (2.38")	130-4956	220-0627	230-0619
120-6427	200-1119 (2.38")	130-4956	220-0627	230-0619
120-7197	200-1119 (2.38")	130-4956	220-0627	230-0619

- NOTES: (1) REFERENCE FRONT OF MANUAL FOR GENERAL ORDERING INFORMATION
 (2) THE BASE PART NUMBER CAN BE RIGHT HAND OR LEFT HAND MOUNTED
 (3) SLIDE PIN KIT P/N 230-0619 IS REQUIRED FOR INSTALLATION AND MUST BE ORDERED SEPARATELY
 (4) INCLUDES SLIDE PIN VIBRATION DAMPENERS

WARNING: The user or installer of any product from this catalog must determine its suitability for their intended purpose or application