

# BILLET SUPERLITE 4R/ST RADIAL MOUNT CALIPER



www.wilwood.com

## Caliper Highlights:

The **Billet Superlite 4R/ST** is an extremely rigid, four piston, radial mount design that incorporates Wilwood's latest technology in brake system heat management. With its small piston volumes and large pad capacity, it is ideally suited for rear brake applications in severe duty oval track and road course competition.

The **BSL4R/ST** body is a product of FEA design and stress analysis technology. It is configured for use with 1.25" thick rotors and the substantial pad volume of the 7420 style brake pad. Starting at 5.32 pounds it is the perfect balance between high strength, low deflection, and overall lightweight. Each caliper is fitted with stainless steel pad load plates to reduce wear and provide the smoothest pad operation. A center bridge bolt adds to overall caliper strength and gives easy access to the top loaded pads.



Black

**Thermlock® T1** pistons are used to minimize the direct heat transfer from the brake pads. This configuration has been documented to reduce caliper temperatures by more than 30% without the need for fluid recirculation systems. Use EXP 600 Plus racing brake fluid to guarantee trouble free performance in all extreme conditions.

**BSLR** bracket kits are used to install the **BSLR4/ST** calipers in place of most 3.50" lug mount calipers. Radial mounting simplifies service in the field and the bracket kits provide two planes of adjustment for precise alignment over the disc.

## CALIPER ORDERING INFORMATION:<sup>(1)</sup>

BORE SIZE	DISC WIDTH	FRONT MOUNT PART NO.		REAR MOUNT PART NO.	
		RH	LH	RH	LH
1.3 / 1.12" (44,5/28,4)	1.25" 31,8 mm	120-6541-FS	120-6542-FS	120-6541-RS	120-6542-RS
1.25/1.12" (31,8/28,4)	1.25" 31,8 mm	120-6543-FS	120-6544-FS	120-6543-RS	120-6544-RS

## SL4R/ST BRAKE PAD TYPE 7420 - PAD VOLUME = 4.9 CU. IN.:

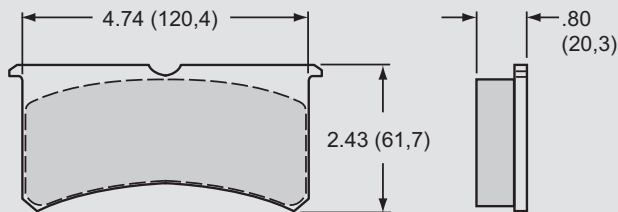

AXLE SET P/N	PAD TYPE / COMPOUND
15A - 5938K	7420 A PolyMatrix
15B - 5939K	7420 B PolyMatrix
15C - 6853K	7420 C PolyMatrix
15E - 6084K	7420 E PolyMatrix
15H - 8114K	7420 H PolyMatrix
15Q - 6829K	7420 Q PolyMatrix
150 - 8854K	7420 10 BP-10 Smart Pad
150 - 9416K	7420 20 BP-20 Smart Pad
150 - 9864K	7420 30 BP-30 Smart Pad
150 - 8323K	7420 SM For Titanium Rotor

## BILLET SUPERLITE 4R/ST RADIAL MOUNT CALIPER, MOUNTING DIMENSIONS:

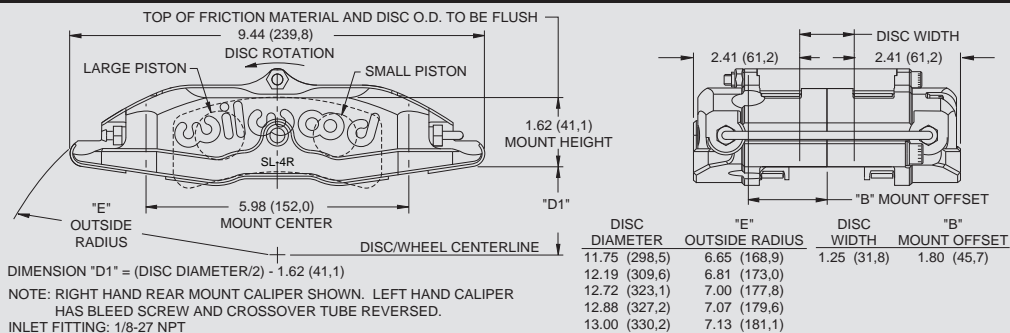

## SERVICE PARTS ORDERING INFORMATION:

CALIPER PART NO.	PISTON	SQ RING KIT (4 PK)	BLEED SCREW KIT (4 PK)	CROSSOVER TUBE KIT (4 PK)	SELF-BLEED TUBE (EA)	BRIDGE BOLT KIT	BRIDGE WEAR PLATE (EA)
120-6541	200-7554 (1.38") 200-7556 (1.12")	130-7218	220-6069	190-5975	190-8310	230-5976	300-5922 (R/H) 300-5923 (L/H)
120-6542	200-7554 (1.38") 200-7556 (1.12")	130-7218	220-6069	190-5975	190-8310	230-5976	300-5922 (R/H) 300-5923 (L/H)
120-6543	200-7555 (1.25") 200-7556 (1.12")	130-7221	220-6069	190-5975	190-8310	230-5976	300-5922 (R/H) 300-5923 (L/H)
120-6544	200-7555 (1.25") 200-7556 (1.12")	130-7221	220-6069	190-5975	190-8310	230-5976	300-5922 (R/H) 300-5923 (L/H)

NOTES: (1) REFERENCE FRONT OF MANUAL FOR GENERAL ORDERING INFORMATION

Brakes are critical safety components, see **warnings** and **disclaimer** on page 129

CALIPERS