



BILLET NARROW MOUNT DYNAPRO CALIPER

Caliper Highlights:

Narrow Mount DynaPro (NDP) forged billet calipers represent the next generation of calipers available as an upgrade or direct replacement for the popular Narrow Mount Dynalite model series with 3.50" mounting. **NDP** calipers combine superior strength with several new performance enhancements to make these the best "Dyna" series calipers ever built.



Black

The strength of the new **DynaPro** is a combination of process and design. **NDP** calipers are stress-flow forged from premium grade billet. Stress-flow forging realigns the grain structure of the metal within the contour of the body design. This process produces a part with superior strength over parts simply machined from straight grained blocks of billet. The FEA generated body design incorporates a highly fortified radial transition that eliminates steps and shoulders between the piston housings and the bridges. Incorporating a radius in this critical area substantially increases resistance to deflection and caliper body separation under load. For additional strength, all **NDP** calipers are fitted with center bridge bolts to provide additional resistance against separation over the center of the pads. Structural deflection and volume displacement testing have proven the efficiency of this innovative design. Reductions in overall deflection, and the subsequent decreases in fluid volume displacement, translate to increased clamping efficiency with less pedal travel. The bottom line is a firm, responsive pedal with outstanding stopping power.

The **DynaPro** is loaded with other enhancements for performance and wider application. The calipers feature Quick-E-Clip pad retainers that support a 7816 type brake pad from the top. Not only does it allow for fast pad service without caliper removal, the bottom pad supports common to the earlier **NDL** models have been removed to create a slimmer profile with more bottom side clearance and easier mounting in tight clearance applications.

Heavy wall stainless steel pistons are used to resist corrosion and slow the heat transfer from the pads. The heavy wall sectional thickness also provides additional strength against backside deflection to provide a firm pedal feel with efficient clamping at all pressures.

Each **NDP** is also fitted with replaceable stainless steel SRS bridge plates. SRS plates eliminate the bridge wear caused by pad gouging to extend the service life of the caliper body. The spring-loading action of the SRS plates also eliminates pad rattle and dampens the vibration harmonics that contribute to squeal during engagement. The package is completed with internal fluid passages and four corner bleed screws that simplify bleeding regardless of the mounting location.

CALIPER ORDERING INFORMATION:⁽¹⁾

BORE SIZE		DISC WIDTH		PART NUMBER
1.75"	44,5 mm	1.25"	31,8 mm	120-9737
1.75"	44,5 mm	.81"	20,6 mm	120-9736
1.75"	44,5 mm	.81"	20,6 mm	120-9736-SI ⁽²⁾
1.75"	44,5 mm	.50"	12,7 mm	120-9735
1.75"	44,5 mm	.38"	9,7 mm	120-9734
1.75"	44,5 mm	.38"	9,7 mm	120-9734-SI ⁽²⁾
1.62"	41,1 mm	1.25"	31,8 mm	120-9733
1.62"	41,1 mm	.81"	20,6 mm	120-9732
1.62"	41,1 mm	.50"	12,7 mm	120-9731
1.62"	44,5 mm	.38"	9,7 mm	120-9730
1.38"	35,1 mm	1.25"	31,8 mm	120-9729
1.38"	35,1 mm	.81"	20,6 mm	120-9728
1.38"	35,1 mm	.50"	12,7 mm	120-9727
1.38"	35,1 mm	.38"	9,7 mm	120-9726
1.12"	28,4 mm	1.25"	31,8 mm	120-9725
1.12"	28,4 mm	.81"	20,6 mm	120-9724
1.12"	28,4 mm	.38"	9,7 mm	120-9722
1.00"	25,4 mm	1.25"	31,8 mm	120-9721
1.00"	25,4 mm	.81"	20,6 mm	120-9720
1.00"	25,4 mm	.38"	9,7 mm	120-9718

NOTES: (1) REFERENCE FRONT OF MANUAL FOR GENERAL ORDERING INFORMATION
(2) SIDE INLET

WARNING: The user or installer of any product from this catalog must determine its suitability for their intended purpose or application



BILLET NARROW MOUNT DYNAPRO CALIPER, MOUNTING DIMENSIONS:

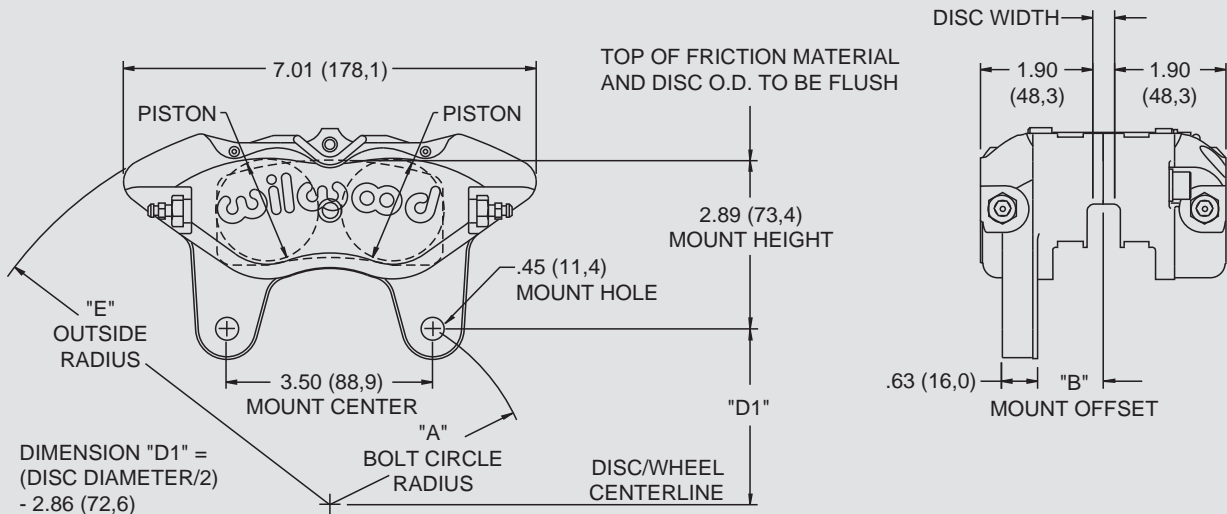

INLET FITTING: 1/8-27 NPT	DISC WIDTH	"B" MOUNT OFFSET	DISC DIAMETER	"A" BOLT CIRCLE RADIUS	"E" OUTSIDE RADIUS
	1.25 (31,8)	1.55 (39,4)	11.75 (298,5)	3.49 (88,6)	6.73 (170,9)
	.81 (20,6)	1.33 (33,8)	12.19 (309,6)	3.68 (93,5)	6.93 (176,0)
	.50 (12,7)	1.17 (29,7)	12.72 (323,1)	3.91 (99,3)	7.18 (182,4)
	.38 (9,6)	1.11 (28,2)			

BILLET NARROW MOUNT DYNAPRO BRAKE PAD TYPE 7816 - PAD VOLUME = 3.0 CU. IN.:

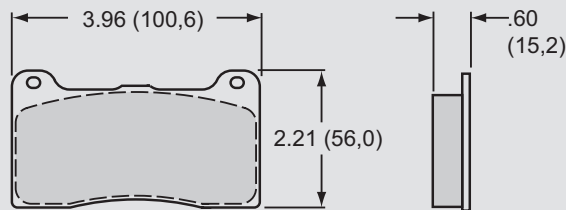

AXLE SET P/N	PAD TYPE / COMPOUND
15A - 7263K	7816 A PolyMatrix
15B - 7264K	7816 B PolyMatrix
15E - 7266K	7816 E PolyMatrix
15Q - 7268K	7816 Q PolyMatrix
150 - 8946K	7816 10 BP-10 Smart Pad
150 - 9419K	7816 20 BP-20 Smart Pad
150 - 9865K	7816 30 BP-30 Smart Pad
150 - 9753K	7816 SM For Titanium Rotor

SERVICE PARTS ORDERING INFORMATION:

CALIPER PART NO.	PISTON	SQ RING KIT (4 PK)	BLEED SCREW KIT (4 PK)	BODY SEAL (EA)	BRIDGE WEAR PLATE (EA)	PAD RETAINER CLIP PIN (EA)	BRIDGE BOLT KIT (EA)
120-9718	200-4657 (1.00")	130-4320	220-0627	210-2582	300-5876	300-9634	230-9982
120-9720	200-4657 (1.00")	130-4320	220-0627	210-2582	300-5876	300-9636	230-9983
120-9721	200-4657 (1.00")	130-4320	220-0627	210-2582	300-5876	300-9638	230-10116
120-9722	200-7513 (1.12")	130-2579	220-0627	210-2582	300-5876	300-9634	230-9982
120-9724	200-7513 (1.12")	130-2579	220-0627	210-2582	300-5876	300-9636	230-9983
120-9725	200-7513 (1.12")	130-2579	220-0627	210-2582	300-5876	300-9638	230-10116
120-9726	200-7516 (1.38")	130-2658	220-0627	210-2582	300-5876	300-9634	230-9982
120-9727	200-7516 (1.38")	130-2658	220-0627	210-2582	300-5876	300-9635	230-10115
120-9728	200-7516 (1.38")	130-2658	220-0627	210-2582	300-5876	300-9636	230-9983
120-9729	200-7516 (1.38")	130-2658	220-0627	210-2582	300-5876	300-9638	230-10116
120-9730	200-7519 (1.62")	130-4346	220-0627	210-2582	300-5876	300-9634	230-9982
120-9731	200-7519 (1.62")	130-4346	220-0627	210-2582	300-5876	300-9635	230-10115
120-9732	200-7519 (1.62")	130-4346	220-0627	210-2582	300-5876	300-9636	230-9983
120-9733	200-7519 (1.62")	130-4346	220-0627	210-2582	300-5876	300-9638	230-10116
120-9734	200-7531 (1.75")	130-2655	220-0627	210-2582	300-5876	300-9634	230-9982
120-9735	200-7531 (1.75")	130-2655	220-0627	210-2582	300-5876	300-9635	230-10115
120-9736	200-7531 (1.75")	130-2655	220-0627	210-2582	300-5876	300-9634	230-9982
120-9737	200-7531 (1.75")	130-2655	220-0627	210-2582	300-5876	300-9638	230-10116